

C.I.P.**9 x 25 Super Auto G**

TAB. IV

Date 91-05-17

Revision 08-09-23

Country of Origin: AT

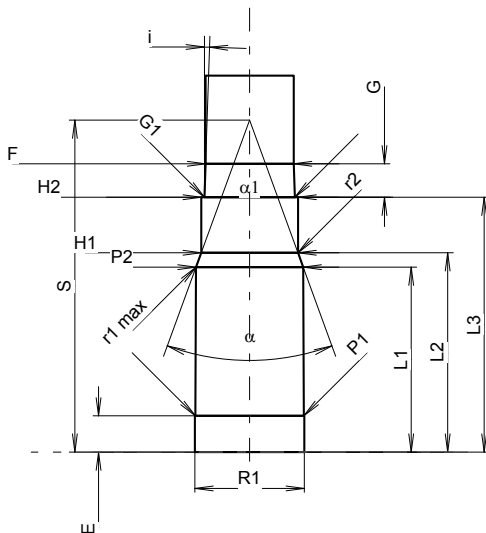
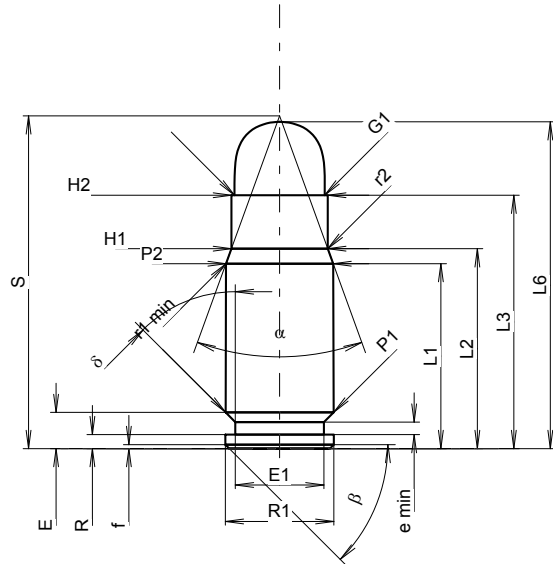

Scale 1.32:1

CARTRIDGE MAXI**Lengths**

L1 ¹⁾ *	=	18.51	-0.20
L2 ¹⁾ *	=	20.00	-0.20
L3 ¹⁾	=	25.35	
L4	=		
L5	=		
L6	=	32.70	

Case Head

R	=	1.40	
R1	=	10.85	
R3	=		
E	=	3.62	
E1	=	8.85	
e min	=	1.25	
delta	=	45°	
f	=	0.40	
beta	=	45°	

Powder Chamber

P1	=	10.80	
P2 ¹⁾ *	=	10.72	-0.20

Junction Cone

alpha	=	39°50'34"	
S	=	33.30	
r1 min	=	0.50	
r2	=	0.50	

Collar

H1 *	=	9.64	
H2 ¹⁾	=	9.63	

Projectile

G1 ¹⁾	=	9.03	
G2	=		
F	=		
L3+G ¹⁾	=	28.70	

Pressures (Energies)**Method Transducer**

Pmax	=	2550 bar	
PK	=	2933 bar	
PE	=	3315 bar	
M	=	12.50	

Miscellaneous Dimensions

Fe ¹⁾ 6)	=	0.20	
delta L	=		

CHAMBER MINI**Lengths**

L1 *	=	18.50	
L2 *	=	19.94	
L3 ¹⁾	=	25.50	

Breech

R	=		
R1	=	10.95	
R2	=		
R3	=		
r	=		

Powder Chamber

E	=	3.62	
P1 ¹⁾	=	10.86	
P2 *	=	10.73	

Junction Cone

alpha ¹⁾	=	40°03'42"	
S	=	33.22	
r1 max	=	0.50	
r2	=	0.50	

Collar

H1 *	=	9.68	
H2 ¹⁾	=	9.68	

Commencement of Rifling

G1 ¹⁾ *	=	9.05	
G ¹⁾ *	=	3.35	
alpha1	=	180°	
h	=		
s	=		
i ¹⁾	=	1°58'	
w	=		

Barrel

F ¹⁾ *	=	8.82	
Z ¹⁾	=	9.02	

Grooves

b	=	2.49	
N	=	6	
u	=	250.00	
Q	=	62.61	mm ²

Dimensions in << mm >>
 Dimensions and Tolerances for Proof Barrels
 see Appendix CR 1.

Notes: 1) Check for safety reasons
 6) Headspace on Case Mouth
 * Basic dimensions